

ENGINEERING

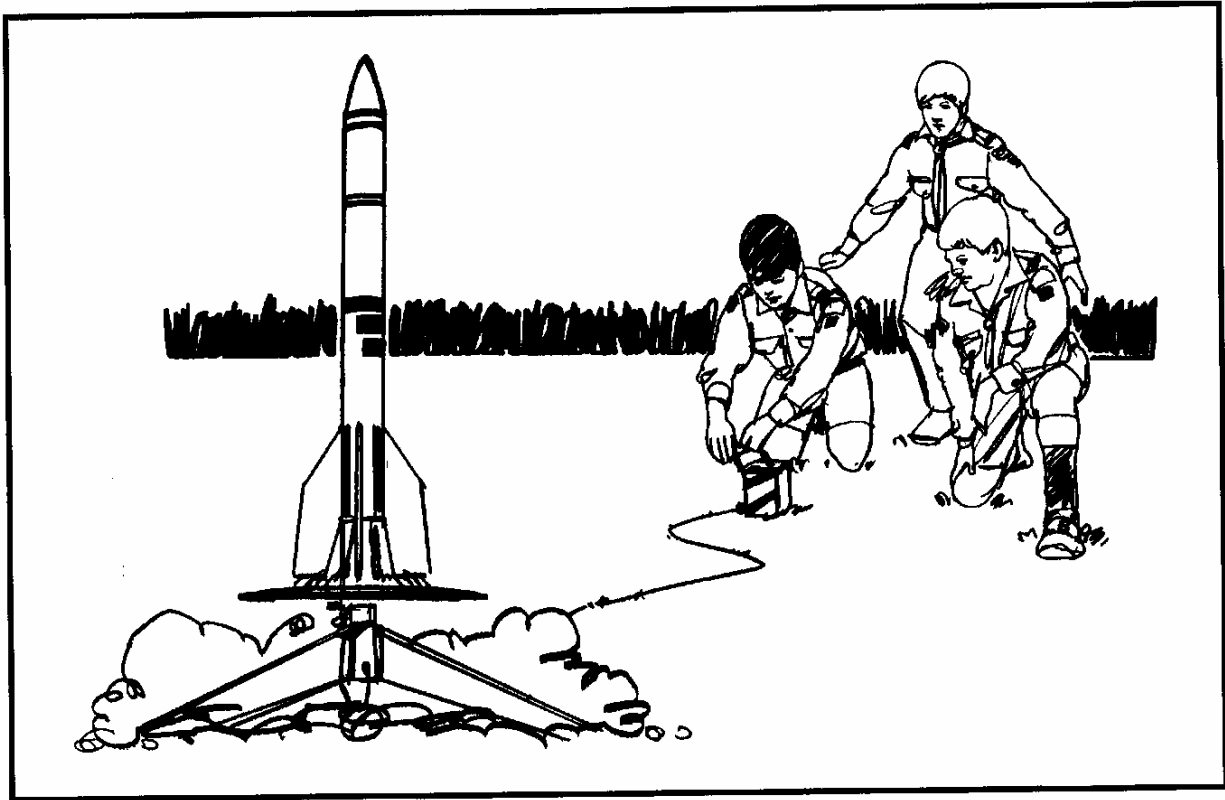

Engineering covers a variety of fields as broad as all outdoors—or indoors, for that matter. Virtually everything we use in the course of a normal day has an engineer's stamp on it.

In Scouting, we specialize in “wilderness engineering”—the art of building useful things with rope and timber. Your Scouts will probably want to try their hand at it this month.

For Scouts who enjoy making things, recommend that they try to earn the Engineering merit badge. It will expose them to various facets of engineering, and it may lead them to work on such other merit badges as Computers, Drafting, Electricity, and Electronics.

The big event will be a campout during which patrols can do some wilderness engineering and enjoy interpatrol competitions.

SCOUTING OUTCOMES

This month's patrol and troop activities should give your Scouts

- Enhanced outdoor skills, especially in knot-tying, lashings, and engineering
- A greater understanding of the importance of conservation

- An understanding of some of the principles of engineering as they build temporary structures and camp equipment
- Enhanced self-confidence

ADVANCEMENT OPPORTUNITIES

By month's end, all Scouts should have met many of their basic pioneering and camping requirements through First Class. Depending on the campout activities, they may also complete all or part of the following rank requirements:

Tenderfoot

- Outdoor—cooking, hiking, camping
- Citizenship—flag ceremonies
- Patrol/troop participation—patrol identification
- Personal development—Scout Oath and Law

Second Class

- Outdoor—cooking, camping, hiking
- Citizenship—flag ceremonies
- Patrol/troop participation—patrol identification
- Personal development—Scout Oath and Law

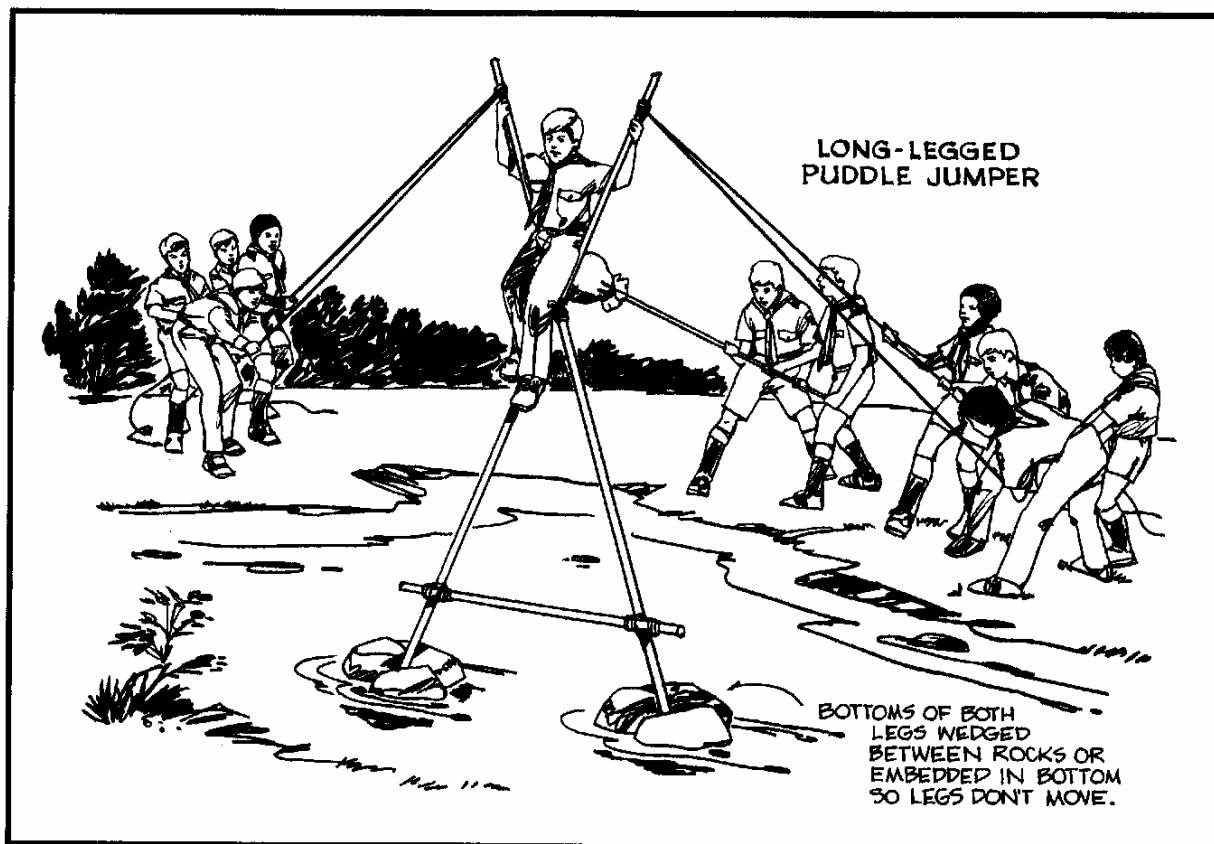

First Class

- Outdoor—cooking, camping, nature, hiking
- Citizenship—flag ceremonies
- Patrol/troop participation—patrol identification
- Personal development—Scout Oath and Law

Merit Badges. Older Scouts can concentrate on the Camping and Pioneering merit badges this month; they should be able to complete many of the requirements. Depending on activities during the campout, they may also cover requirements in Cooking, Hiking, Pioneering, Wilderness Survival, and other outdoor-related merit badges.

PARENT/GUARDIAN PARTICIPATION

The patrol leaders' council may involve parents in the program feature this month by

- Asking those qualified to help with instruction for camping, pioneering, and engineering skills
- Inviting them on the campout
- Asking them to provide transportation to the campsite

PATROL LEADERS' COUNCIL

The patrol leaders' council should meet during the early part of the previous month to plan troop activities for this program feature. If you don't complete all items on the following agenda, continue planning at patrol leaders' council meetings after each troop meeting.

- Decide on a campout site. Remember that you will need a supply of poles and small limbs for pioneering projects. Such materials, cut to size, are available at some Scout camps. If your council's camp does not have them, make sure you can get permission to obtain suitable materials elsewhere. Do not cut trees at any site without the owner's permission.
- Plan the special activities for the campout. See the ideas on these pages. If special gear will be needed, assign someone to obtain it; seek help from the troop committee if necessary.
- Inventory the troop's camping equipment, if not done recently.
- Plan details of troop meetings for the month. Assign patrol demonstrations, covering skills that will be needed for the campout activities.
- Practice knots and lashing, if equipment is available.

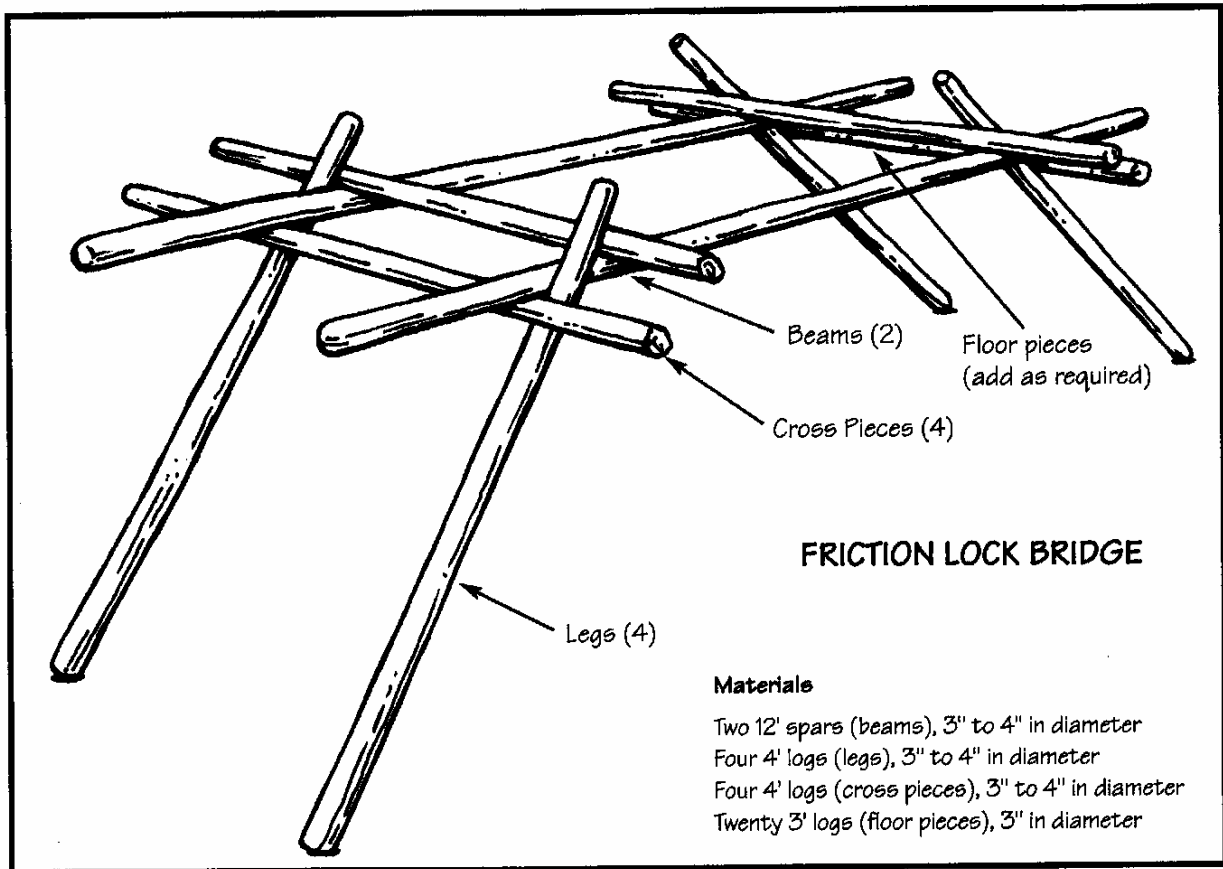

FEATURE EVENT

Engineering Outing

During this campout, the troop can build pioneering projects engineered by the experienced Scouts or demonstrate various "engineering" projects. Examples: a scaled-down version of a wind generator and how it stores energy in batteries, or a solar energy battery charger. Or Scouts could design, make, and demonstrate model rockets, cars, or homes during the campout.

Prepare a sketch or drawing on a computer. Take the drawing or sketch and build the project. See if your design really works.

CAMPOUT GAMES

LOG HITCHING RACE

Equipment: A log, 6 inches in diameter, 5 feet long; 20 to 30 feet of ¼-inch rope; a timepiece to time the race.

Method: In turn, each patrol ties a timber hitch and a half hitch on the log and drags it around a turning point 50 feet away and back to the start. A judge times each performance.

Scoring: The patrol with the fastest time wins.

LASHING RELAY

Equipment: For each patrol, lashing rope and tree spars, each about 2 to 3 inches in diameter, 6 to 10 feet long.

Method: Patrols line up, relay fashion, facing their spars and rope. A judge stands near their equipment. On signal, the first Scout in each patrol runs to the judge and is told to tie one lashing—square, diagonal, or shear. When he has completed the lashing to the judge's satisfaction, he unties the lashing and runs back to touch off the next patrol member. The relay continues until all have run.

Scoring: The first patrol finished wins.

HIGH HOT CHOCOLATE

Equipment: For each patrol, poles and lashing ropes for a four-legged tower that is 8 feet high with a 4'-by-4' square platform at the top; water, small pot, cup, spoon, instant chocolate mix, 2'-by-2' square of plywood, sand for fire bed.

Method: Each patrol assembles its tower. One member then climbs up and makes a fireplace of sand on the

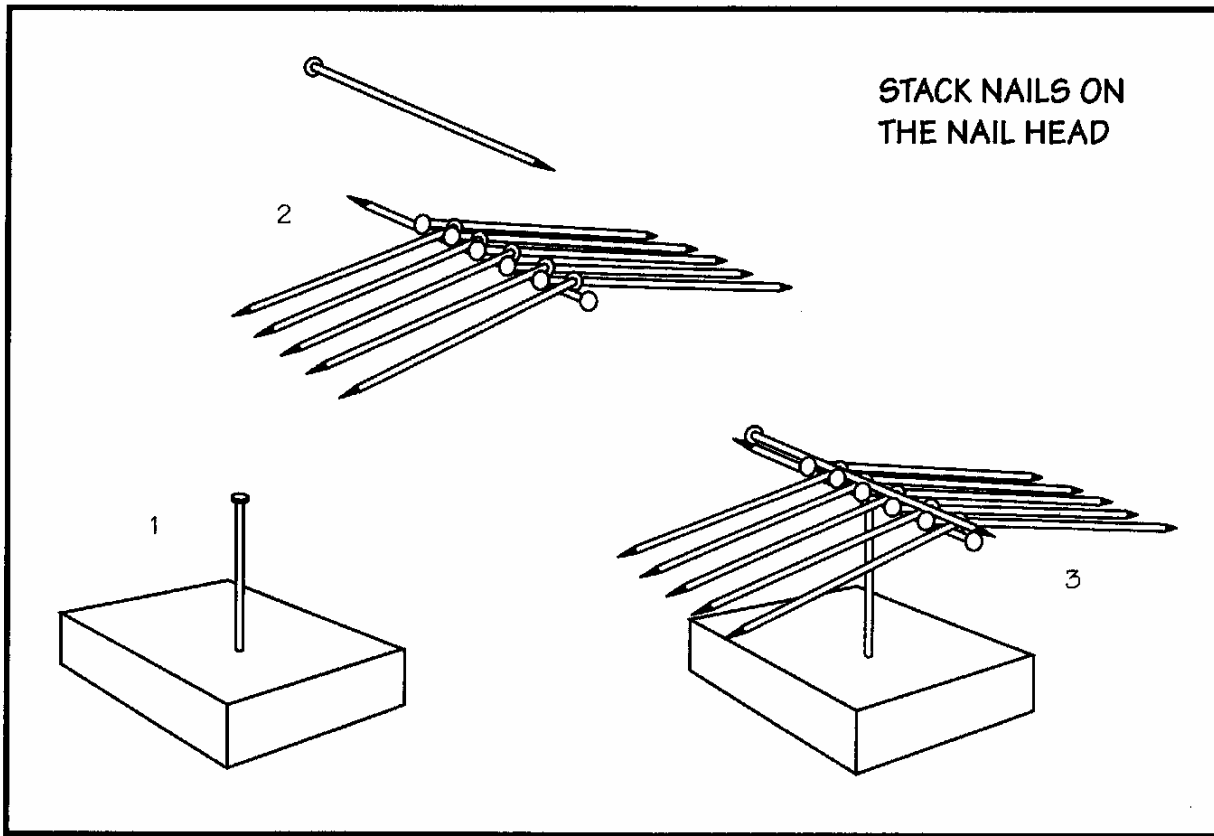

plywood square. He builds a small fire on the sand, boils a cup of water, and makes hot chocolate.

Scoring: The first patrol to give the Scoutmaster a cup of hot chocolate wins.

Friction Lock Bridge

Equipment

- Two 12' spars (beams), 3" to 4" in diameter
- Four 4' logs (legs), 3" to 4" in diameter
- Four 4' logs (cross pieces), 3" to 4" in diameter
- Twenty 3' logs (floor pieces), 3" in diameter

A friction lock bridge is a fun engineering project for a patrol to construct. Put the two 12-foot spars in place, and then the legs, and lock in the beams. (See the diagram.) Cover with flooring.

Stack Nails on the Nail Head

Drive a 4-inch nail into a block of wood about one-half inch. Have 12 other 4-inch nails, and challenge the group to stack all 12 nails on the head of the nail in the block. Allow Scouts to make an attempt. You will need to stress that no other objects such as rubber bands are allowed. After a few attempts, show how to stack the nails. Lay one nail on a flat surface. Place five nails on the nail laying flat, with the head about one-quarter inch past the nail laying flat. Place five more nails in the opposite direction, in between each nail. The one remaining nail should be placed on top, in the opposite direction of the nail laying flat. Carefully pick up the two nails and the other 10 will lock into place. Center the nails on the nail head on the block of wood. (See the diagram.)

ENGINEERING

TROOP MEETING PLAN

Date _____ Week 1

ACTIVITY	DESCRIPTION	RUN BY	TIME
Preopening _____ minutes	Have some professional engineers in different fields bring in the "tools" of their trade to show what they do. These may be blueprints that show what kind of designing they do.		
Opening Ceremony _____ minutes	<ul style="list-style-type: none"> • Form the troop into a horseshoe. • Hold a uniform inspection. • Repeat the Scout Oath. 		
Skills Instruction _____ minutes	<ul style="list-style-type: none"> • New Scouts practice tying the clove hitch, square knot, and bowline. Do Rescue Race. (See the Games section of the <i>Troop Program Resources</i>.) • Experienced Scouts arrange to visit an engineering firm or engineering department in industry. Or, design several pioneering projects that could be built with Scout staves. • Older Scouts work on the Venture program or study ropes and knots needed for rappelling (<i>Fieldbook</i>). 		
Patrol Meetings _____ minutes	Discuss plans for the outing this month and make sure everyone knows his assignments. If the outing will be an overnigher, begin meal planning and patrol duty roster, and plan for equipment distribution and tent requirements. Any Scouts who have not been camping will need extra help. All other patrols work on plans for activities towards the next rank advancement.		
Interpatrol Activity _____ minutes	Play Reactor Transport. (See the Games section of the <i>Troop Program Resources</i> .)		
Closing _____ minutes Total 90 minutes of meeting	<ul style="list-style-type: none"> • Sing "Scout Vespers." • Scoutmaster's Minute. • Retire colors. 	SM	
After the Meeting	Patrol leaders' council reviews the next meeting and plans for the outing. Begin work on next month's program feature.		

**Troop Program Resources for Scout Troops and Varsity Teams, Supply No. 33588*

ENGINEERING

TROOP MEETING PLAN

Date _____ Week 2

ACTIVITY	DESCRIPTION	RUN BY	TIME
Preopening _____ minutes			
Opening Ceremony _____ minutes			
Skills Instruction _____ minutes	<ul style="list-style-type: none"> • New Scouts review knots practiced last week and begin learning lashings. Do Knot-Tying Relay. (See the Games section of the <i>Troop Program Resources</i>.) • Experienced Scouts continue work on pioneering projects or visit an engineering firm. • Older Scouts work on the Venture program or plan to catch and cook fish for a meal on the troop's outing. 		
Patrol Meetings _____ minutes	Review assignments for the campout. First-time campers continue working on hiking and camping techniques. All other patrols continue to work on advancement activities for the outing. Practice interpatrol activities.		
Interpatrol Activity _____ minutes	Do Stack the Nails on the Nail Head, found in the introduction of this program feature.		
Closing _____ minutes Total 90 minutes of meeting	<ul style="list-style-type: none"> • Sing "Scout Vespers." • Scoutmaster's Minute. • Retire colors. 	SM	
After the Meeting	Patrol leaders' council reviews the next meeting and plans for the outing. Continue work on next month's program feature.		

*Troop Program Resources for Scout Troops and Varsity Teams, Supply No. 33588

ENGINEERING

TROOP MEETING PLAN

Date _____ Week 3

ACTIVITY	DESCRIPTION	RUN BY	TIME
Preopening _____ minutes			
Opening Ceremony _____ minutes			
Skills Instruction _____ minutes	<ul style="list-style-type: none"> • New Scouts practice use and care of woods tools, and learn how to make firelays. Continue work on lashings. • Experienced Scouts make assignments to get necessary staves, spars, and ropes for pioneering projects on the campout. • Older Scouts work on the Venture program or assist with instruction of younger Scouts. Or, visit an engineering firm. 		
Patrol Meetings _____ minutes	Finalize the menu for the outing and make sure everyone knows what to bring. Review clothing and equipment needs and collect necessary fees. Practice interpatrol activities.		
Interpatrol Activity _____ minutes	Play Log-Rolling Relay. (See the Games section of the <i>Troop Program Resources</i> .) *		
Closing _____ minutes Total 90 minutes of meeting	<ul style="list-style-type: none"> • Scoutmaster's Minute. • Retire colors. 	SM	
After the Meeting	Patrol leaders' council reviews the next meeting and plans for the outing. Continue work on next month's program feature.		

*Troop Program Resources for Scout Troops and Varsity Teams, Supply No. 33588

ENGINEERING

TROOP MEETING PLAN

Date _____ Week 3

ACTIVITY	DESCRIPTION	RUN BY	TIME
Preopening _____ minutes			
Opening Ceremony _____ minutes			
Skills Instruction _____ minutes	<ul style="list-style-type: none"> • New Scouts practice use and care of woods tools, and learn how to make firelays. Continue work on lashings. • Experienced Scouts make assignments to get necessary staves, spars, and ropes for pioneering projects on the campout. • Older Scouts work on the Venture program or assist with instruction of younger Scouts. Or, visit an engineering firm. 		
Patrol Meetings _____ minutes	Finalize the menu for the outing and make sure everyone knows what to bring. Review clothing and equipment needs and collect necessary fees. Practice interpatrol activities.		
Interpatrol Activity _____ minutes	Play Log-Rolling Relay. (See the Games section of the <i>Troop Program Resources</i> . *)		
Closing _____ minutes Total 90 minutes of meeting	<ul style="list-style-type: none"> • Scoutmaster's Minute. • Retire colors. 	SM	
After the Meeting	Patrol leaders' council reviews the next meeting and plans for the outing. Continue work on next month's program feature.		

*Troop Program Resources for Scout Troops and Varsity Teams, Supply No. 33588

ENGINEERING

TROOP OUTDOOR PROGRAM PLAN

Date _____

TIME	ACTIVITY	RUN BY
Friday evening	Load gear at meeting location, leave for campsite. Plan only a light meal en route.	SPL
	Arrive at campsite; off-load equipment. Set up patrol sites. Stow gear and set up camp.	SPL/PL
Saturday 6:30 A.M.	Cooks and assistants up. Prepare breakfast. (Cooks should be working on First and Second Class requirements.)	Cooks, assistants
7:00 A.M.	Everyone else up. Take care of personal hygiene, air tents, hang out sleeping bags.	
7:30 A.M.	Breakfast	
8:00 A.M.	Clean up.	Cooks
	Patrols put up the gear for morning activities, clean up patrol site.	
8:30-11:30 A.M.	Engineering demonstration, pioneering projects.	
11:30 A.M.	Cooks prepare lunch.	Cooks
Noon	Lunch	
12:30 P.M.	Clean up.	Cooks
1 P.M.	Pioneering projects	SPL
4:30 P.M.	Start dinner preparation.	Cooks
5:30 P.M.	Dinner	SPL
6:00 P.M.	Clean up.	Cooks
8:00 P.M.	Campfire	
9:00 P.M.	Cracker barrel	
10:00 P.M.	Lights out	
Sunday 6:30 A.M.	Cooks and assistants up. Prepare breakfast. (Cooks should be working on First and Second Class requirements.)	Cooks, assistants
7:00 A.M.	Everyone else up. Take care of personal hygiene, air tents, hang out sleeping bags.	
7:30 A.M.	Breakfast	
8:00 A.M.	Clean up.	Cooks
	Patrols put up the gear for morning activities, clean up patrol site.	

TIME	ACTIVITY	RUN BY
8:30 A.M.	Worship service	
9:00-11:00 A.M.	Patrol games—use four games from the Games section of the <i>Troop Program Resources</i> . *	
11:00 A.M.	Break camp.	
Special equipment needed	Scout staves, rope, spars, troop camping equipment	

*Troop Program Resources for Scout Troops and Varsity Teams, Supply No. 33588